

Choice of Pesticide and Application Methods

[Pesticide Selection](#)

[Application Method and Choice of Equipment](#)

[Hand-Operated Sprayers](#)

[Nozzle Selection](#)

[Calibrating Sprayers](#)

[Cleaning and Maintenance of Sprayers](#)

Pesticide Selection

The following is a guide to the major points which should be borne in mind when selecting a pesticide.

Pest Identification and Population

Identify the pest accurately then refer to product manuals, advisors, or literature to identify the product or products that will do the job. When scouting pests, it is also important to accurately assess population levels. If pest populations are below economic threshold levels there may be no reason to spray at all.

Identification and Population of Beneficial Organisms

It is also a good idea to assess the kinds of numbers of beneficial organisms in the field. If their numbers are high they may be able to control the pest without spraying. Additionally, spraying may do more damage to the beneficials resulting in a more serious pest problem than would have occurred without spraying. If beneficials are present and spraying is indicated, you should choose a pesticide that has the least effect on beneficials.

Level of Infestation/Stage of Crop Development

Assess the number of pests or immature stages such as eggs, larvae and whether the observed level poses an immediate threat. Government

department (Ministry of Agriculture or Health) often set "thresholds" above which it is necessary to control pests. It is, however, important to relate the infestation to the stage of crop development.

After establishing the nature and level of the infestation and having identified a range of products that will bring it under control, it is necessary to select the most appropriate product. The following criteria should be applied:

Selectivity

High selectivity is not very common but if possible, choose the pesticide that will cause the least damage to non-target species.

Mammalian Toxicity

Products that are of low toxicity to man and other mammals are preferable to those which pose significant hazard.

Method of Application

Match the product to the available equipment for application. Certain formulations cannot be used with knapsack or other hydraulic sprayers.

Persistence

Check the product label for information about the persistence or length of activity. In certain circumstances, it is useful to have a product which will remain active for several days or even weeks. If an infestation occurs shortly before harvest, choose a product that will not leave residues which may be harmful to consumers. Check for the pre-harvest interval in the product labels.

Mode of Action

Bear in mind that products work in different ways. Knowledge of pests and how a certain product works can help you maximise the effectiveness of the product.

Avoidance of Resistance

With chronic infestations, i.e. those which may continue throughout the season and which may need several applications for even partial control, do not spray repeatedly with the same product or family of products. For example, early in the season use a relatively selective product to minimise damage to predators and other beneficial insects. Later in the season choose a broad spectrum if necessary.

Supplementary points:

- Remember that the product label contains important and useful information. ALWAYS READ THE PRODUCT LABEL BEFORE USING ANY PRODUCTS.

Application Method and Choice of Equipment

Insecticides and fungicides are usually applied as foliar sprays, and herbicides are mostly sprayed either onto the foliage or the soil. Thus **spraying of liquid and wettable powder formulations is the most common method of application** and consequently a wide variety of hand-operated and power-driven spray apparatus has been developed over the years.

Other formulations such as granules, dusts and fumigants require different equipment for their application or none at all. For example, **granules can either be applied by mechanical spreaders or broadcast by hand.**

In Asian countries, most pesticides are applied with small, hand-operated, hydraulic sprayers or hand-held spinning disc sprayers.

Depending on the type of agricultural practices and economic development of the area, mist-blowers and power-operated hydraulic or rotary cage sprayers mounted on tractor or aircraft may also be used extensively.

Supplementary points:

- When selecting a sprayer, it is good to identify the range of uses to which it will be put. Certain types of sprayers are suitable for certain types of pesticides. For example, diaphragm pump type lever-operated knapsack sprayer is ideally suited for herbicide application.
- For safety, it is also very important to investigate the particular make of machine. For example, stainless steel tanks are better than galvanised metal since they are not subject to corrosion.
- FAO has published standards for knapsack sprayers. A simple set of essential safety features and characteristics of the different types of sprayers is provided in the FAO Minimum Standards: Portable (Operator-carried) sprayers at - <http://www.fao.org/docrep/X2244E/X2244E00.htm>

Hand-Operated Sprayers

There are various types of hand-operated sprayers, but they can be broadly categorised into two groups:

1. Sprayers with hydraulic nozzles designed with systems to generate pressure at the nozzle to achieve correct atomisation. With lever-operated sprayers the main tank is not pressurised, but spray pressure is generated in a pressure chamber by constant pumping. With compression sprayers, the whole tank is pressurised prior to spraying.

Lever-Operated Knapsack Sprayers

- Diaphragm Pump Knapsack Sprayers

A. Upstroke

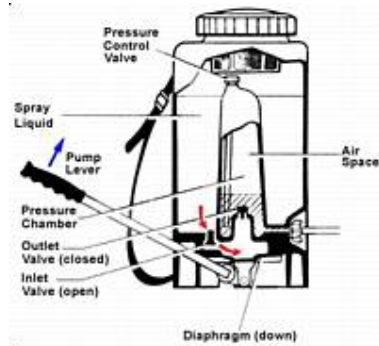

B. Downstroke

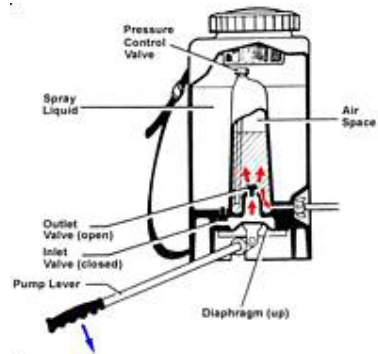

- Piston Pump Knapsack Sprayers

A. Upstroke

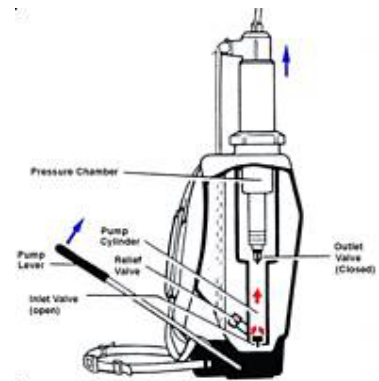

B. Downstroke

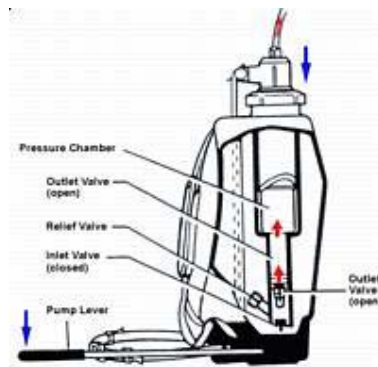

Compression Sprayers

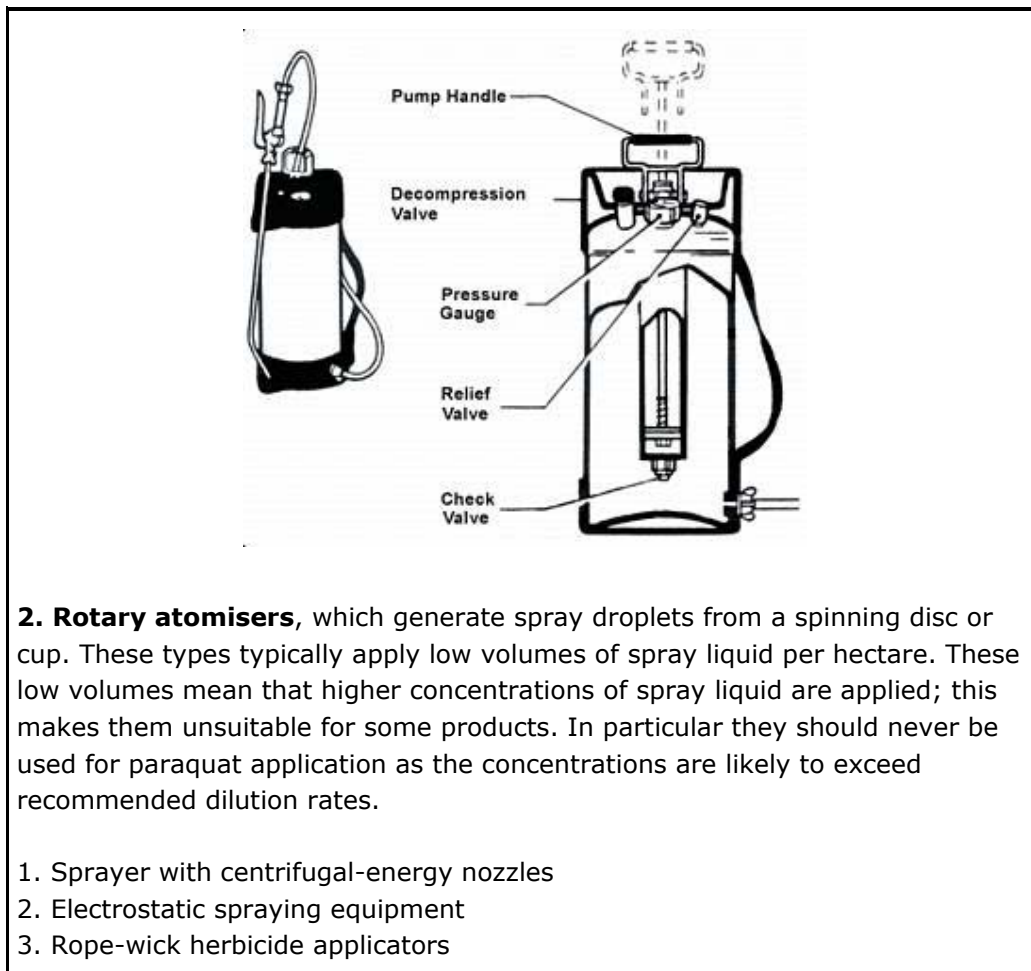

Supplementary points:

- Hand-operated, hydraulic sprayers or hand-held spinning disk sprayers are commonly use in Asian countries in applying pesticides.
- Sprayers with centrifugal-energy nozzles are also termed "controlled droplet application (CDA) sprayers"
- Rope-wick herbicide applicators were developed specifically to apply low volumes of highly concentrated herbicides, to weeds that grow taller than crops. The herbicide solution is rubbed on any weeds that come into contact with the rope wick.

Nozzles

The nozzle is one of the most important parts of the sprayer, since it is doing the job of producing the spray droplets. Adjustable nozzles are commonly supplied with knapsack sprayers but these should never be used for pesticide application as they do not allow safe calibration. It is quite easy to change their rates and patterns and spray operators tend to accidentally and randomly adjust them during spraying.

Basic Designs of Hydraulic Nozzles:

Solid-cone Nozzle

This nozzle sprays a circular (conical) pattern of droplets, which are evenly distributed over the whole circle with the centre being filled too. It typically produces smaller spray angles and larger droplets and so is used for spot treatments of herbicides or situations where greater downward penetration of spray is required, but tends to be used mainly for tractor boom spraying.

Hollow-cone Nozzle

This nozzle produces a circular pattern with almost no spray droplets in the centre. They are best suited to spraying crop foliage because droplets approach the leaves from more directions giving good coverage over the many different target surfaces in a crop. This means they are most commonly used for insecticide and fungicide spraying in crops.



Regular Flat-fan Nozzle

This nozzle with a flat spray-tip sprays a narrow oval pattern with lighter (tapered) edges. The narrow droplet pattern makes the nozzle ideal for spraying flat surfaces. It is suited for the application of herbicides and for spraying walls for vector control.



Even Flat-fan Nozzle

This nozzle with an even spray-tip provides uniform distribution across the entire width of the spray band. The even pattern makes it suitable for band spraying in pre- and post-emergence herbicide application and for the spraying of walls.



Flood-jet Nozzle

Also called as deflector, impact or anvil, produces a wide-angle flat-fan spray pattern. More droplets land at the outer edges of the



fan and the pattern is rather uneven. Impact nozzles are operated at low pressure for pre- and post-emergence herbicide and liquid fertilizer applications. At high pressure, very small droplets can be produced.

Supplementary points:

- The solid and hollow cone spray patterns depend on two components: nozzle tip or orifice disc and core or swirl plate.
- The materials most often used for the manufacture of nozzle bodies and caps are:

Stainless steel - recommended for use with all spray materials

Nylon - resists corrosion and abrasion; swells when exposed to some solvents.

Aluminium - subject to corrosion and has a short life

Brass - not resistant to abrasive materials such as wettable powders

- The four main types of nozzle named after the source of energy used in the spraying system are as follows: hydraulic energy type, gaseous energy type, centrifugal energy type, electrostatic energy type

Other Information:

- Some manufacturers now produce nozzles with the outer part made from a plastic which is cheap and can be colour coded, and a small insert including the orifice, made from a more resistant but more expensive material such as stainless steel or ceramic.

Calibrating Hand-Operated Knapsack Sprayer

Accurate calibration of the sprayer is an important part of every spraying operation to ensure that the pesticide is applied at the rate specified on the product label. Failure to calibrate has 3 major consequences:

- Too much chemical is applied. This is wasteful and expensive and can lead to environmental problems or crop residues being unacceptably high.
- Too little chemical is applied. This means that the pest or weed may not be controlled properly and perhaps may require re-treatment which is again costly and time-wasting. Under-dosing may also lead to rapid development of pest resistance.

- Considerable amounts of unused spray liquid left over after the spray operation. Disposal of left over spray liquid is difficult and time consuming and poses risks to the person disposing, to other humans and to the environment.

Calibration Procedure

The aim of calibration is to apply the correct amount of spray mix to a given area of crop or land - in litres/hectare (l/ha) or litres/acre, gallons/acre etc.

This is dependent on the following variables:

- The concentration of product in the water in the tank or dilution rate (usually measured in gram/litre g/l) or millilitres/litre (ml/m)
- The nozzle output or flow rate measured in litres/minute (l/min).
- The spray width in metres - which is itself dependent on two factors: the nozzle spray angle; and the height of the nozzle above the target
- The walking speed of the spray operator (in mph, km/h or m/sec)
- The total area to be sprayed in hectares (ha) or acres

The above factors should be considered when calibrating your sprayer.

Supplementary points:

- [Click here](#) for the steps in calibrating a knapsack sprayer.

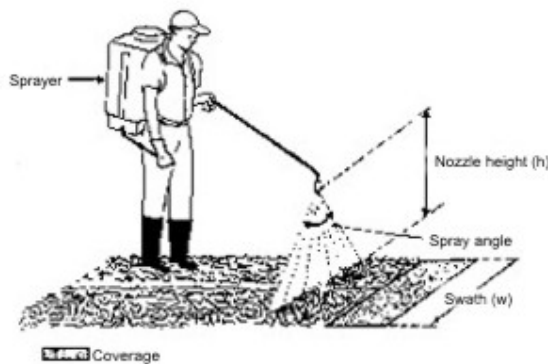

- There are various ways of using the measurements made of the variables listed above to achieve the correct output per unit area. What the farmer or spray operator needs to know is: flow rate, swath width, usual walking speed, how much of a particular product needs to be added to the tank to achieve the correct dilution rate (in litre or ml per tankful) to give the correct product rate for the whole area needing treatment.
- Study the Directions for Use section of the pesticide label to find out how much pesticide you should apply. If the labeling lists a range of possible amounts, use the least amount that will achieve good control.

Sometimes consultants, industry organizations, pest or pesticide specialists, Cooperative Extension agents, university specialists, or pesticide dealers will recommend appropriate amounts.

Cleaning/Maintenance of Knapsack Sprayer

Pesticides are expensive and it is therefore in the farmer's best interest to use them efficiently. In addition sprayers are costly items and **routine cleaning and checking of equipments will prolong the life of sprayer and avoid the application of more pesticide than necessary.**

Cleaning SHOULD ALWAYS be carried out at the end of the day's spraying, or if changing from one product type to another.

Sprayers SHOULD NEVER be left with spray mix inside, as the mixture may degrade making it unsuitable for re-use, and the chemicals may damage the components of the sprayer. For example it may cause seals or valves to perish or swell and jam. In addition, a sprayer left full of spray mix is an unacceptable hazard to other people, animals and foodstuffs.

When cleaning the sprayer, it is important that the operator wears protective clothing; at least a long-sleeved shirt and long trousers, eye protection, gloves, boots and preferably an apron. Only after the sprayer has been stored away and all waste has been removed should the operator take off the protective clothing before washing and changing clothes.

Sprayers should be kept locked away from children, food and farm animals, and measures taken to prevent rats from chewing hoses and other parts.

Many small hydraulic sprayers are preferably stored upside-down with the lid removed to allow complete drainage of the container.

When any part of the sprayer does not function properly, correct the defect immediately.